



### For medium and high security requirements

For access control, steering visitors, and passage into secured areas – MPH wing gates are the ideal solution for the rapid separation of persons when high security is required. Variants with enlarged passage widths also make the MPH suitable for wheelchairs, prams, and the transport of materials.

Passage takes place without contact. Photoelectric switches reliably detect users and open the wings before they come into contact with them. The barriers close automatically after passage.

The sensitive impact detection of the MHTM™ drive ensures maximum personal safety. In addition, the photoelectric switches contribute towards security: they register the passage of persons attempting to follow through, passage in the wrong direction, or the lack of authorisation and trigger an alarm.

The wing gates can be used bi-directionally and can be regulated with all common access control systems. The barrier elements are available with toughened or laminated safety glass.



#### High separation security

The high gate elements prevent climbing over and thus effectively delimit areas from one another. The desired level of security can be individually adapted via differing gate heights.



#### Innovative drive technology

The MHTM™ drive unit is maintenance-free, energy-efficient and quiet. Sensitive impact detection ensures maximum personal safety.

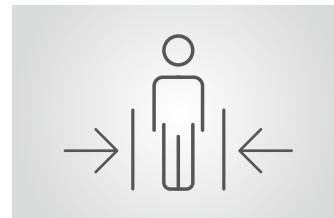

#### Reliable processes

Photoelectric switches in the passage reliably detect persons and objects. They enable non-contact passage and trigger an alarm in the case of improper use.

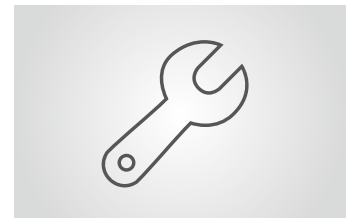

#### Easily accessible components

All the control and drive components necessary for operation are accommodated in the lockable central segment – considerably simplifying commissioning and maintenance.

# MPH

## Wing gate

- > High separation reliability with rapid passage of persons
- > Comfortable non-contact passage
- > Simple integration of all common access control systems
- > Automatic opening if power fails
- > Wide variants suitable for wheelchairs, prams, bicycles, and material transport
- > Designed for 10 million opening and closing actions



Technical data	MPH 112 (Standard)	MPH 112 (Wide Lane)
Passage width	520 mm	910 mm
Gate heights	1200, 1500 or 1800 mm	1200, 1500 or 1800 mm
Opening/closing time	0.6 – 1.2 s	1.0 – 1.4 s
Drive technology	MHTM™	MHTM™
Voltage	110 – 240 VAC, 50/60 Hz	110 – 240 VAC, 50/60 Hz
Power consumption	Maximum 100 W	Maximum 300 W
Duty cycle	100 %	100 %
Housing dimensions (L x W x H)	1300 x 300 x 1035 mm	1300 x 520 x 1035 mm
Housing material	Stainless steel 1.4301/SS304	Stainless steel 1.4301/SS304
Enclosure rating	IP 32	IP 32
Temperature range	0 to +45 °C	0 to +45 °C

### Options

Barrier elements	Toughened or laminated safety glass, gate heights of 1200, 1500 or 1800 mm, customer-specific door element designs through imprints and adhesive foils
Attachments	Customer-specific access control systems

### Potential applications

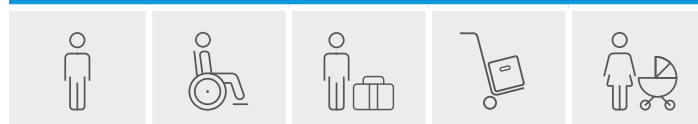

## Dimensional drawings

MPH 112 (Standard)  
with 520 mm passage width

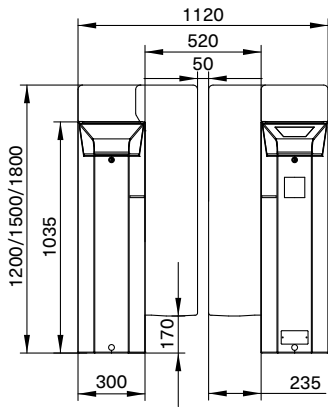

MPH 112 (Wide Lane)  
with 910 mm passage width

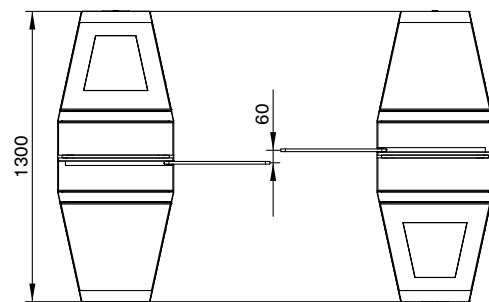
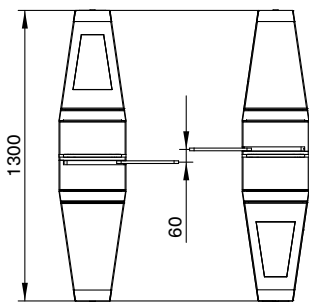
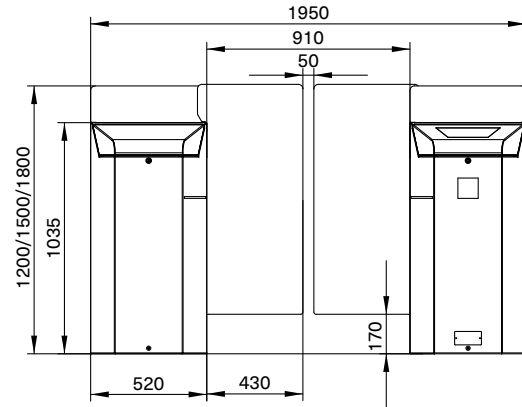

## Line configuration with combinable modules

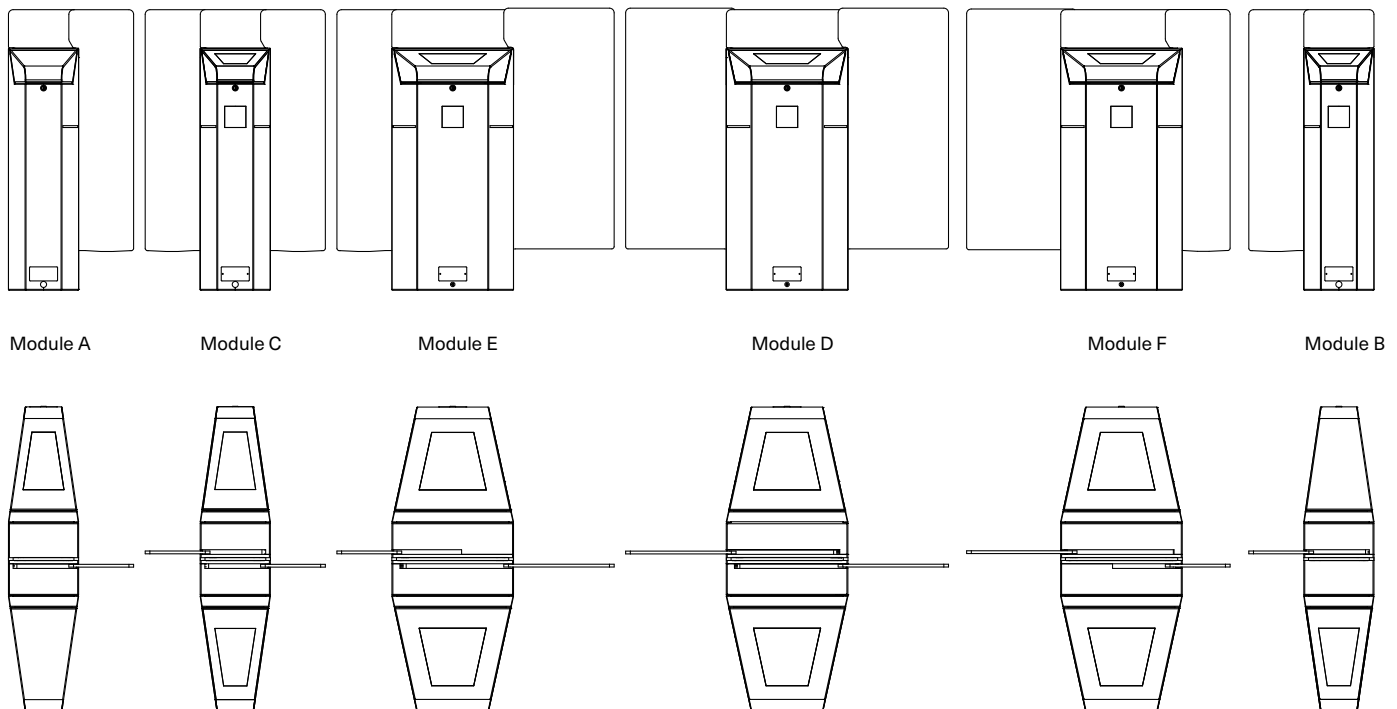

# Access to Progress

Magnetic stands for pioneering products – in every way. Our access control systems for vehicles or pedestrians clear the way for thousands of people every day – at car parks, toll gates, stations, airports and in buildings. Our technology is also pioneering, however: with innovative drives, intelligent control systems and well thought-out details it provides maximum safety and longevity. Are you also on the path to Magnetic?



## Vehicle barriers

Access barriers  
Parking barriers  
Toll barriers  
Special barriers



## Pedestrian gates

Turnstiles  
Swing gates  
Tripod gates  
Retractable gates  
Wing gates



## Terminals

Cars  
Trucks

*Germany*  
**MAGNETIC AUTOCONTROL GMBH**  
Grienmatt 20  
79650 Schopfheim  
Phone +49 7622 695-5  
Fax +49 7622 695-800  
E-mail [info@magnetic-germany.com](mailto:info@magnetic-germany.com)

*Australia*  
**MAGNETIC AUTOMATION PTY LTD**  
38 Metrolink Circuit  
Campbellfield, VIC 3061  
Phone +61 3 9339 2900  
E-mail [info@magnetic-oz.com](mailto:info@magnetic-oz.com)

*Austria*  
**FAAC GMBH**  
Münchner Bundesstraße 123  
5020 Salzburg  
Phone +43 662 853395-0  
E-mail [at.info@faacgroup.com](mailto:at.info@faacgroup.com)

*Benelux countries*  
**FAAC BENELUX NV/SA**  
Industriezone 3B  
8490 Jabbeke  
Belgium  
Phone +32 50 320202  
E-mail [info@magnetic-benelux.com](mailto:info@magnetic-benelux.com)

*Brazil*  
**MAGNETIC AUTOCONTROL LTDA**  
Av. Salim Antônio Curiati, 136  
04690-050 – São Paulo  
Phone +55 11 5660 8500  
E-mail [info@magnetic-br.com](mailto:info@magnetic-br.com)

*China*  
**MAGNETIC CONTROL SYSTEMS CO., LTD**  
No. 3 Building, No. 51  
Lane 1159, Kang Qiao (East) Road  
Kang Qiao Industrial Zone, Shanghai  
Phone +86 21 68182970  
E-mail [info@magnetic-cn.com](mailto:info@magnetic-cn.com)

*France*  
**FAAC FRANCE**  
377 Rue Ferdinand Perrier  
69808 St Priest Cedex  
Phone +33 4 72 21 86 89  
E-mail [info@magnetic-fr.com](mailto:info@magnetic-fr.com)

*India*  
**MAGNETIC FAAC INDIA PVT LTD.**  
PRS Centre  
Plot No. 373 to 376, 2nd Floor (West Wing)  
1st Cross Street, Nehru Nagar  
Old Mahabalipuram Road  
Kottivakkam (Opp Rayala Technopark, Perungudi)  
Chennai 600041  
Phone +91 44 421 23297  
E-mail [info@magnetic-india.com](mailto:info@magnetic-india.com)

*Middle East*  
**FAAC MIDDLE EAST FZE**  
Dubai Silicon Oasis  
PO Box 54886  
Dubai  
United Arab Emirates  
Phone +971 4 3724193  
E-mail [info@magnetic-uae.com](mailto:info@magnetic-uae.com)

*N. and S. America (excl. Brazil)*  
**FAAC INTERNATIONAL, INC**  
3160 Murell Road  
Rockledge, FL 32955  
USA  
Phone +1 321 635 8585  
E-mail [info@magnetic-usa.com](mailto:info@magnetic-usa.com)

*Scandinavia*  
**FAAC NORDIC AB**  
Box 125  
284 22 Perstorp  
Sweden  
Phone +46 435 77 95 03  
E-mail [info@magnetic-nordic.com](mailto:info@magnetic-nordic.com)

*Southeast Asia*  
**MAGNETIC CONTROL SYSTEMS SDN. BHD**  
No. 17, Jalan Anggerik Mokara 31/54  
Taman Perindustrian Kota Kemuning  
40460 Shah Alam  
Selangor Darul Ehsan  
Malaysia  
Phone +60 3 5123 0033  
E-mail [info@magnetic-malaysia.com](mailto:info@magnetic-malaysia.com)