



For rapid automatic ticket inspection

This MPW design has been specially developed for inspecting tickets at public transport facilities, where it is important to achieve rapid and non-contact individualisation. The housings, made of high-quality polished stainless steel are 2 m long and available in two widths for standard or wheelchair-accessible passageways. All components for operation are integrated within the barrier, considerably accelerating installation and commissioning. The MPW offers sufficient space for the reading devices and ticket systems used in public transport systems, and can be adapted to customer requirements, if desired.

The innovative MHTM™ drive is maintenance-free, energy-efficient and very quiet. Injuries and damage are reliably prevented due to its sensitive impact detection that meets European standards. The integrated control system can be operated with all common ticket systems and offers bidirectional operation as standard. A large number of photoelectric switches in the passageway dependably monitor the passage process and detect unauthorised use, such as persons attempting to follow through, passage in the wrong direction, or unauthorised entry.



Rapid separation of persons

Short opening times of 0.6 seconds make MPW swing gates suitable for rapid and reliable ticket inspections with high passenger numbers.



Innovative drive technology

The MHTM™ drive unit is maintenance-free, energy-efficient and quiet. Sensitive impact detection ensures maximum personal safety and meets stringent European standards.

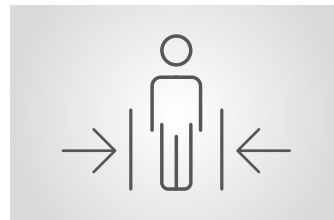

Reliable processes

Photoelectric switches in the passageway reliably detect persons and objects. They enable non-contact passage and trigger an alarm on improper use.

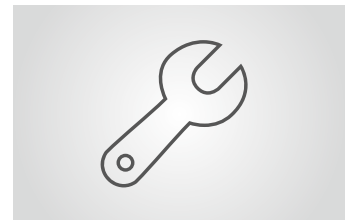

Easily accessible components





All the control and drive components necessary for operation are accommodated in the barrier itself and can be configured using DIP switches or a PC interface – considerably simplifying commissioning and maintenance.

- > Designed for 10 million opening and closing intervals
- > Short opening times of 0.6 seconds for high throughflow frequency
- > Slender design and comfortable non-contact passage
- > Simple integration of all common ticket inspection systems
- > Automatic opening if power fails or alarm sounds
- > Space-saving installation of multiple applications
- > Wide variants suitable for wheelchairs and bicycles



Technical data	MPW 112 (Standard)	MPW 112 (Wide Lane)
Passageway width	550 mm	900 mm
Opening/closing time	> 0.6 s (depending on barrier element)	> 1.0 s (depending on barrier element)
Drive technology	MHTM™	MHTM™
Voltage	110–240 VAC, 50/60 Hz	110–240 VAC, 50/60 Hz
Power consumption	Maximum 120 W	Maximum 120 W
Duty cycle	100 %	100 %
Housing dimensions (L x W x H)	2000 x 200 x 1016 mm	2000 x 200 x 1016 mm
Housing material	Stainless steel 1.4301/SS304	Stainless steel 1.4301/SS304
Enclosure rating	Up to IP54	Up to IP54
Temperature range	0 to +45°C	0 to +45°C

Options	
Barrier element materials	Customer-specific barrier elements made of tempered safety glass, acrylic glass or fireproof PU foam
Components	Customer-specific card readers and ticket systems, passage indicator (GED), tariff display (concession light), interlocking of barrier elements in voltage-free state
Housings	Customer-specific adaptations

Potential applications				
				

Dimensional drawings

MPW 112 (Standard) with 550 mm passageway width

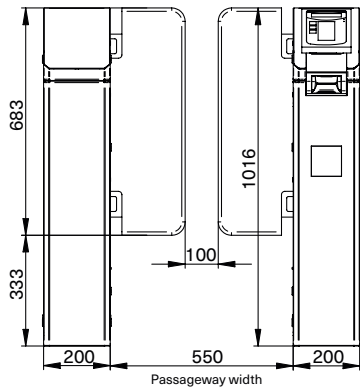

MPW 112 (Wide Lane) with 900 mm passageway width

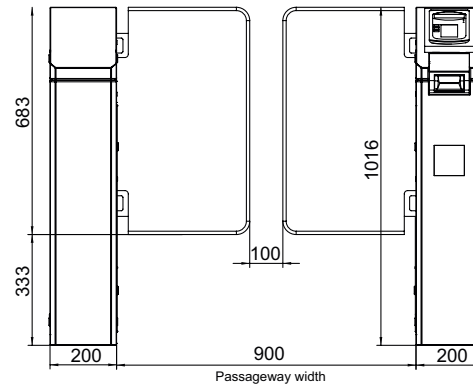

Side view

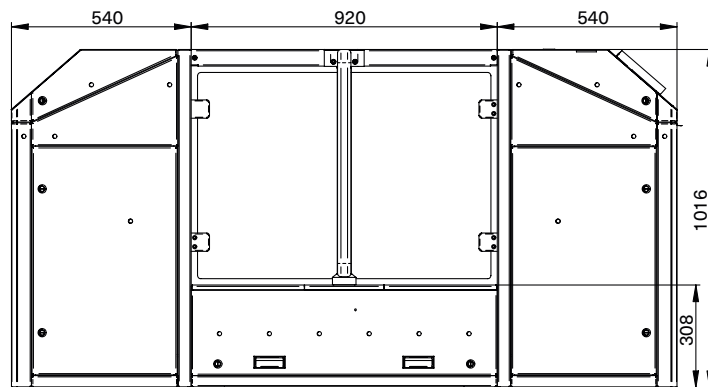

Line configuration with combinable modules

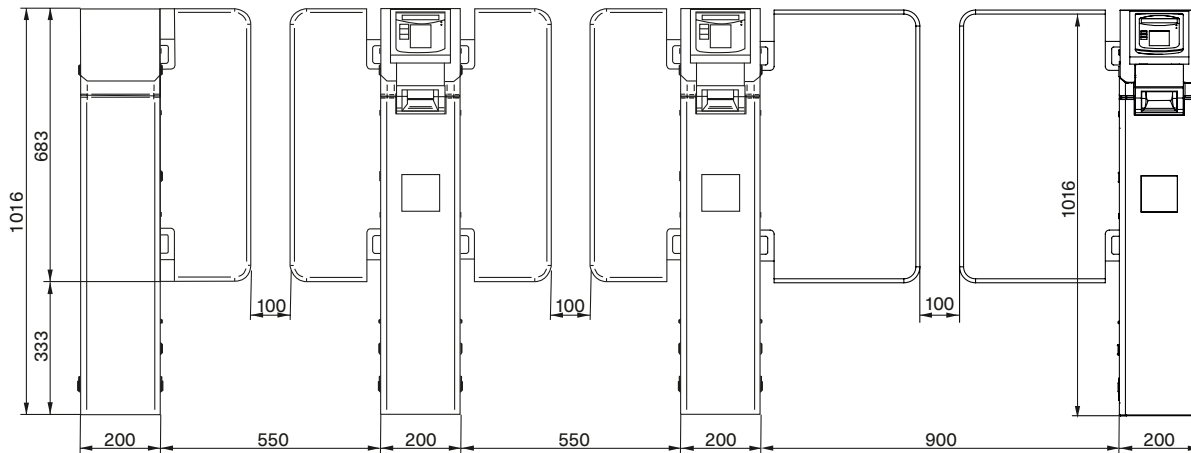

Access to Progress

Magnetic stands for pioneering products – in every way. Our access control systems for vehicles or pedestrians clear the way for thousands of people every day – at car parks, toll gates, stations, airports and in buildings. Our technology is also pioneering, however: with innovative drives, intelligent control systems and well thought-out details it provides maximum safety and longevity. Are you also on the path to Magnetic?



Vehicle barriers

Access barriers
Parking barriers
Toll barriers
Special barriers



Pedestrian gates

Turnstiles
Swing gates
Tripod gates
Retractable gates
Wing gates



Terminals

Cars
Trucks

Germany
MAGNETIC AUTOCONTROL GMBH
Grienmatt 20
79650 Schopfheim
Phone +49 7622 695-5
Fax +49 7622 695-800
E-mail info@magnetic-germany.com

Australia
MAGNETIC AUTOMATION PTY LTD
38 Metrolink Circuit
Campbellfield, VIC 3061
Phone +61 3 9339 2900
E-mail info@magnetic-oz.com

Austria
FAAC GMBH
Münchner Bundesstraße 123
5020 Salzburg
Phone +43 662 853395-0
E-mail at.info@faacgroup.com

Benelux countries
FAAC BENELUX NV/SA
Industriezone 3B
8490 Jabbeke
Belgium
Phone +32 50 320202
E-mail info@magnetic-benelux.com

Brazil
MAGNETIC AUTOCONTROL LTDA
Av. Salim Antônio Curciati, 136
04690-050 – São Paulo
Phone +55 11 5660 8500
E-mail info@magnetic-br.com

China
MAGNETIC CONTROL SYSTEMS CO., LTD
No. 3 Building, No. 51
Lane 1159, Kang Qiao (East) Road
Kang Qiao Industrial Zone, Shanghai
Phone +86 21 68182970
E-mail info@magnetic-cn.com

France
FAAC FRANCE
377 Rue Ferdinand Perrier
69808 St Priest Cedex
Phone +33 4 72 21 86 89
E-mail info@magnetic-fr.com

India
MAGNETIC FAAC INDIA PVT LTD.
PRS Centre
Plot No. 373 to 376, 2nd Floor (West Wing)
1st Cross Street, Nehru Nagar
Old Mahabalipuram Road
Kottivakkam (Opp Rayala Technopark, Perungudi)
Chennai 600041
Phone +91 44 421 23297
E-mail info@magnetic-india.com

Middle East
FAAC MIDDLE EAST FZE
Dubai Silicon Oasis
PO Box 54886
Dubai
United Arab Emirates
Phone +971 4 3724193
E-mail info@magnetic-uae.com

N. and S. America (excl. Brazil)
FAAC INTERNATIONAL, INC
3160 Murell Road
Rockledge, FL 32955
USA
Phone +1 321 635 8585
E-mail info@magnetic-usa.com

Scandinavia
FAAC NORDIC AB
Box 125
284 22 Perstorp
Sweden
Phone +46 435 77 95 03
E-mail info@magnetic-nordic.com

Southeast Asia
MAGNETIC CONTROL SYSTEMS SDN. BHD
No. 17, Jalan Anggerik Mokara 31/54
Taman Perindustrian Kota Kemuning
40460 Shah Alam
Selangor Darul Ehsan
Malaysia
Phone +60 3 5123 0033
E-mail info@magnetic-malaysia.com