

MPH

High swing gates for ticket inspection

MAGNETIC[®]
ACCESS TO PROGRESS



For medium and high security requirements

For access control, steering visitors, and passage into secured areas – MPH wing gates are the ideal solution for the rapid separation of persons when high security is required. Variants with enlarged passageway widths also make the MPH suitable for wheelchairs, prams, and the transport of materials.

Passage takes place without contact. Photoelectric switches reliably detect users and open the wings before they come into contact with them. The barriers close automatically after passage.

The sensitive impact detection of the MHTM™ drive ensures maximum personal safety. In addition, the photoelectric switches contribute towards security: they register the passage of persons attempting to follow through, passage in the wrong direction, or the lack of authorisation, and trigger an alarm.

The wing gates can be used bi-directionally and can be regulated with all common access control systems. The barrier elements are available with toughened or laminated safety glass.



Highly reliable separation

The high gate elements prevent climbing over and thus effectively delimit areas from one another. The desired level of security can be individually adapted via differing gate heights.



Innovative drive technology

The MHTM™ drive unit is maintenance-free, energy-efficient and quiet. Sensitive impact detection ensures maximum personal safety.

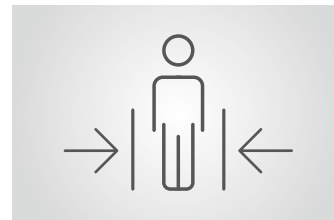

Reliable processes

Photoelectric switches in the passage reliably detect persons and objects. They enable non-contact passage and trigger an alarm on improper use.

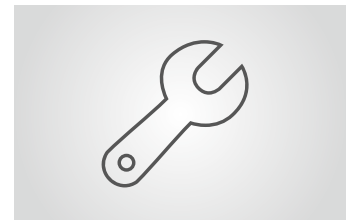

Easily accessible components

All the control and drive components necessary for operation are accommodated in the lockable central segment – considerably simplifying commissioning and maintenance.

MPH





High swing gates for AFC

- > Designed for 10 million opening and closing intervals
- > High separation reliability with rapid passage of persons
- > Comfortable non-contact passage
- > Simple integration of all common ticket inspection systems
- > Automatic opening if power fails
- > Wide variants suitable for wheelchairs, prams and material transport



Technical data	MPH 112 (Standard)	MPH 112 (Wide Lane)
Passageway width	520 mm	910 mm
Gate heights	1200, 1500 or 1800 mm	1200, 1500 or 1800 mm
Opening/closing time	0.6 – 1.2 s	1.0 – 1.4 s
Drive technology	MHTM™	MHTM™
Voltage	110 – 240 VAC, 50/60 Hz	110 – 240 VAC, 50/60 Hz
Power consumption	Maximum 100 W	Maximum 300 W
Duty cycle	100 %	100 %
Housing dimensions (L x W x H)	2000 x 300 x 1035 mm	2000 x 520 x 1035 mm
Housing material	Stainless steel 1.4301/SS304	Stainless steel 1.4301/SS304
Enclosure rating	IP 32	IP 32
Temperature range	0 to +45°C	0 to +45°C

Options	
Barrier elements	Toughened or laminated safety glass, gate heights of 1200, 1500 or 1800 mm, customer-specific door element designs through overprints and adhesive foils
Components	Customer-specific card readers and ticket systems, passage indicator (GED), tariff display (concession light), interlocking of barrier elements in voltage-free state
Housings	Customer-specific adaptations

Potential applications				
				

Dimensional drawings

MPH 112 (Standard)
with 520 mm passageway width

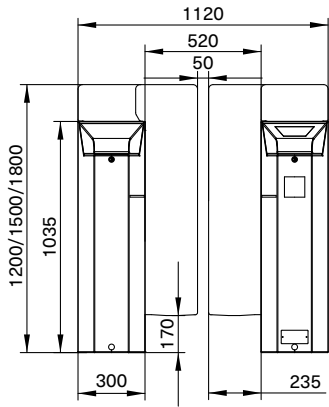

MPH 112 (Wide Lane)
with 910 mm passageway width

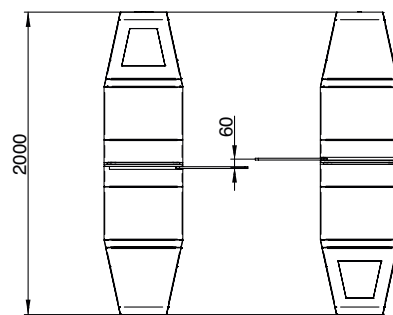
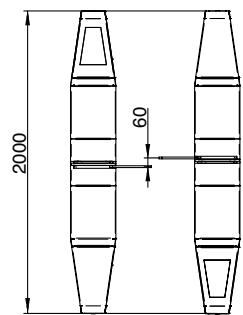
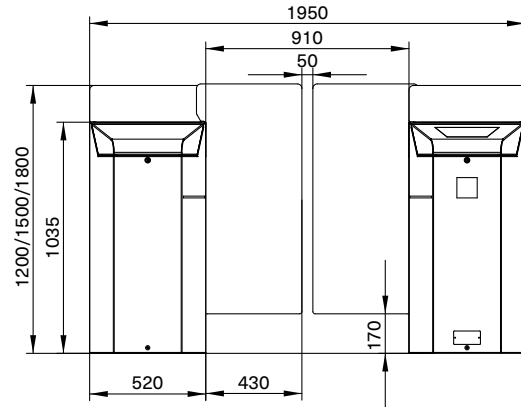

Line configuration with combinable modules

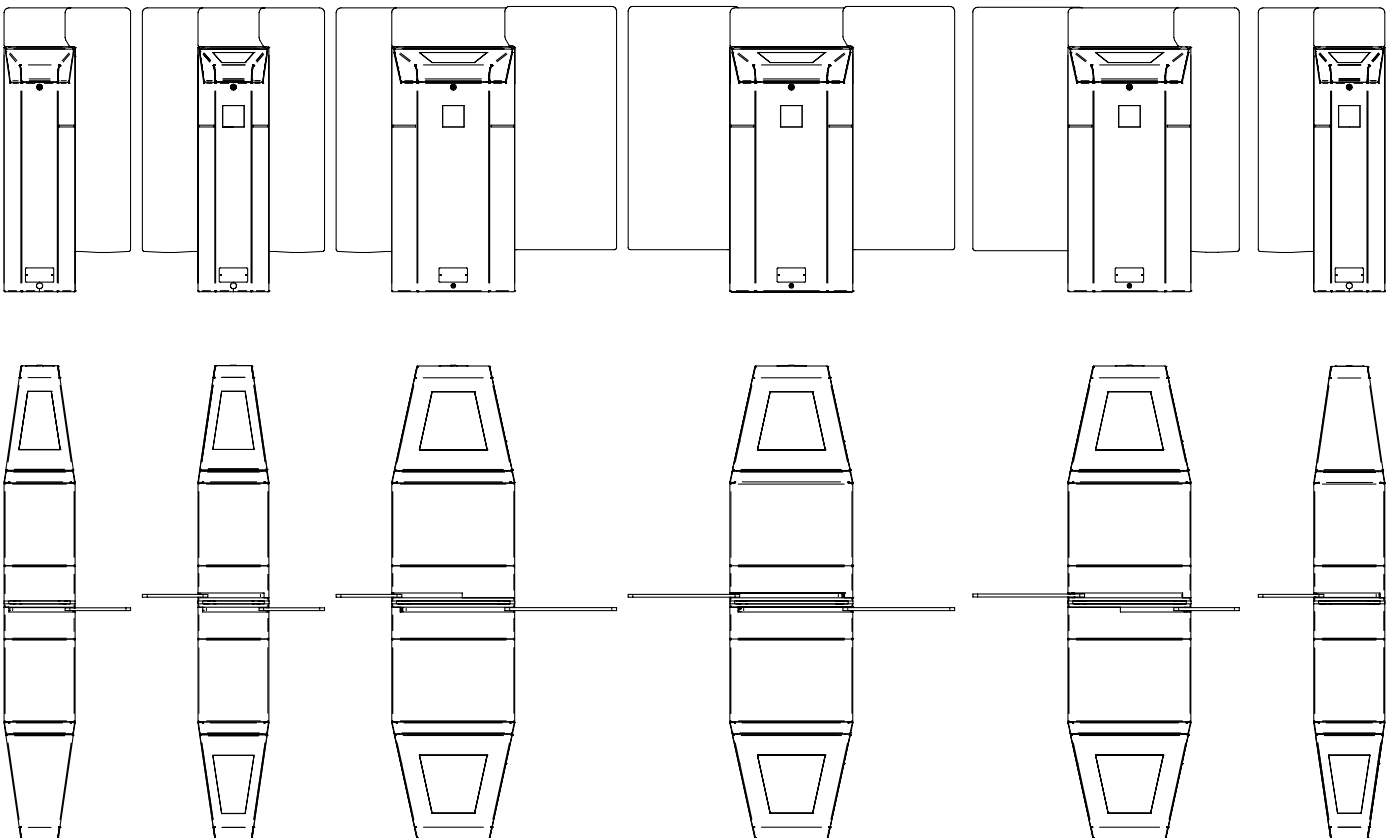

Access to Progress

Magnetic stands for pioneering products – in every way. Our access control systems for vehicles or pedestrians clear the way for thousands of people every day – at car parks, toll gates, stations, airports and in buildings. Our technology is also pioneering, however: with innovative drives, intelligent control systems and well thought-out details it provides maximum safety and longevity. Are you also on the path to Magnetic?



Vehicle barriers

Access barriers
Parking barriers
Toll barriers
Special barriers



Pedestrian gates

Turnstiles
Swing gates
Tripod gates
Retractable gates
Wing gates



Terminals

Cars
Trucks

Germany
MAGNETIC AUTOCONTROL GMBH
Grienmatt 20
79650 Schopfheim
Phone +49 7622 695-5
Fax +49 7622 695-800
E-mail info@magnetic-germany.com

Australia
MAGNETIC AUTOMATION PTY LTD
38 Metrolink Circuit
Campbellfield, VIC 3061
Phone +61 3 9339 2900
E-mail info@magnetic-oz.com

Austria
FAAC GMBH
Münchner Bundesstraße 123
5020 Salzburg
Phone +43 662 853395-0
E-mail at.info@faacgroup.com

Benelux countries
FAAC BENELUX NV/SA
Industriezone 3B
8490 Jabbeke
Belgium
Phone +32 50 320202
E-mail info@magnetic-benelux.com

Brazil
MAGNETIC AUTOCONTROL LTDA
Av. Salim Antônio Curiati, 136
04690-050 – São Paulo
Phone +55 11 5660 8500
E-mail info@magnetic-br.com

China
MAGNETIC CONTROL SYSTEMS CO., LTD
No. 3 Building, No. 51
Lane 1159, Kang Qiao (East) Road
Kang Qiao Industrial Zone, Shanghai
Phone +86 21 68182970
E-mail info@magnetic-cn.com

France
FAAC FRANCE
377 Rue Ferdinand Perrier
69808 St Priest Cedex
Phone +33 4 72 21 86 89
E-mail info@magnetic-fr.com

India
MAGNETIC FAAC INDIA PVT LTD.
PRS Centre
Plot No. 373 to 376, 2nd Floor (West Wing)
1st Cross Street, Nehru Nagar
Old Mahabalipuram Road
Kottivakkam (Opp Rayala Technopark, Perungudi)
Chennai 600041
Phone +91 44 421 23297
E-mail info@magnetic-india.com

Middle East
FAAC MIDDLE EAST FZE
Dubai Silicon Oasis
PO Box 54886
Dubai
United Arab Emirates
Phone +971 4 3724193
E-mail info@magnetic-uae.com

N. and S. America (excl. Brazil)
FAAC INTERNATIONAL, INC
3160 Murell Road
Rockledge, FL 32955
USA
Phone +1 321 635 8585
E-mail info@magnetic-usa.com

Scandinavia
FAAC NORDIC AB
Box 125
284 22 Perstorp
Sweden
Phone +46 435 77 95 03
E-mail info@magnetic-nordic.com

Southeast Asia
MAGNETIC CONTROL SYSTEMS SDN. BHD
No. 17, Jalan Anggerik Mokara 31/54
Taman Perindustrian Kota Kemuning
40460 Shah Alam
Selangor Darul Ehsan
Malaysia
Phone +60 3 5123 0033
E-mail info@magnetic-malaysia.com